

# RPLIDAR S2L

Low-cost 360 Degree Laser Range Scanner

## Introduction and Datasheet

Model: S2M1-R2L

32K

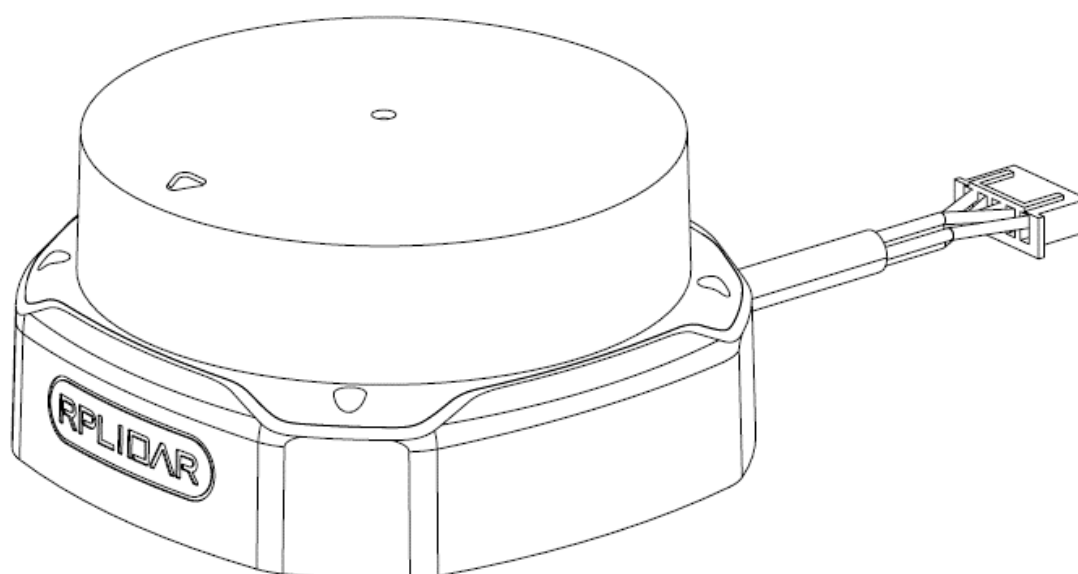

2024-04-12 rev.2.1



<b>CONTENTS</b> .....	<b>1</b>
<b>INTRODUCTION</b> .....	<b>3</b>
SYSTEM COMPOSITION AND CONNECTION .....	4
MECHANISM.....	4
SAFETY AND SCOPE .....	6
DATA OUTPUT.....	6
HIGH-SPEED SAMPLING PROTOCOL AND ITS COMPATIBILITY.....	7
APPLICATION SCENARIOS.....	8
<b>SPECIFICATION</b> .....	<b>9</b>
MEASUREMENT PERFORMANCE .....	9
LASER POWER SPECIFICATION.....	10
OPTICAL WINDOW.....	10
COORDINATE SYSTEM DEFINITION OF SCANNING DATA .....	11
COMMUNICATION INTERFACE.....	11
MISCELLANEOUS .....	14
<b>SELF-PROTECTION AND STATUS DETECTION</b> .....	<b>15</b>
<b>SDK AND SUPPORT</b> .....	<b>16</b>
<b>MECHANICAL DIMENSIONS</b> .....	<b>17</b>
<b>REVISION HISTORY</b> .....	<b>18</b>
<b>APPENDIX</b> .....	<b>19</b>
IMAGE AND TABLE INDEX .....	19



The RPLIDAR S2L is a next-generation low-cost 360 degree 2D laser scanner (LIDAR) solution developed by SLAMTEC. It can take up to 32000 samples of laser ranging per second with high rotation speed. Equipped with contactless power and signal transmission technology, it breaks the life limitation of traditional LIDAR systems to work stably for a long time.

The RPLIDAR S2L is a 2D laser scanner, which can perform a 2D 360-degree scan within a 18-meter range and produce a 2D point cloud map of the space where it is located. The generated 2D point cloud data can be used in mapping, robot localization, robot navigation, and object/environment modeling.

Compared with other RPLIDAR series, RPLIDAR S2L has a more stable performance when detecting objects in long distances, objects in white or black alternatively, and objects under direct sunlight, which is ideal for map building in the outdoor or indoor environment within a 18-meter ranging radius. Therefore, it can be widely applied in many consumer-oriented business scenarios.

The typical scanning frequency of RPLIDAR S2L is 10Hz (600rpm). With the 10Hz scanning frequency, the sample rate is 32kHz, and the angular resolution is 0.12°.

Due to the improvements in SLAMTEC hardware operating performance and related algorithms, RPLIDAR S2L works well in all indoor environments and outdoor environments with direct sunlight. Meanwhile, before leaving the factory, every RPLIDAR S2L has passed strict testing to ensure the laser output power meets the eye-safety standard of IEC-60825 Class 1.

## System Composition and Connection

The RPLIDAR S2L consists of a range scanner core and the mechanical powering part, which makes the core rotate at a high speed. When it functions normally, the scanner core will rotate and scan clockwise. Users can get the range scan data via the communication interface of the RPLIDAR.

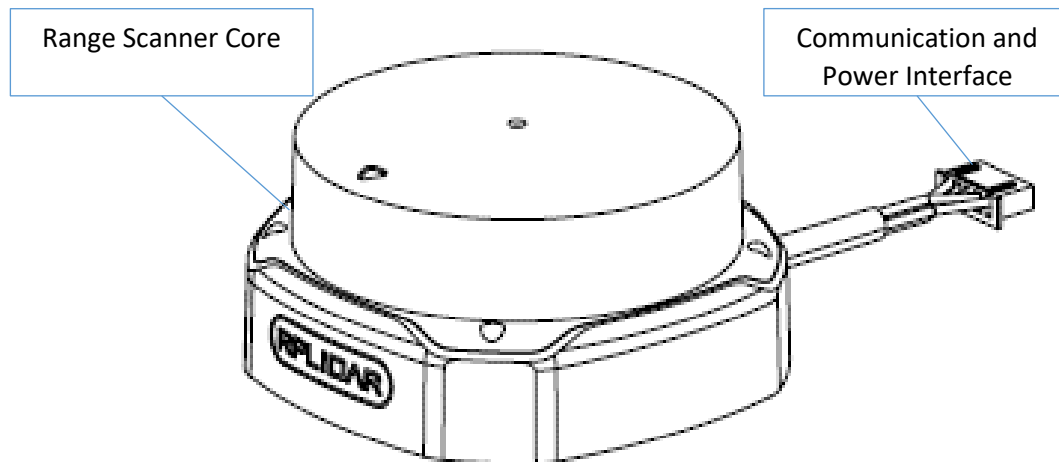

*Figure 1-1 RPLIDAR S2L System Composition*

The RPLIDAR S2L comes with a rotation speed detection and adaptive system. The system automatically adjusts the angular resolution according to the rotating speed. And there is no need to provide a complicated power system for the RPLIDAR. In this way, the simple power supply schema saves the BOM cost. If the actual rotation speed of the RPLIDAR is required, the host system can get the related data via the communication interface.

The detailed specification of the power and communication interface can be found in the following sections.

## Mechanism

The RPLIDAR S2L is based on the laser flight-of-time (TOF) ranging principle and adopts the high-speed laser acquisition and processing hardware developed by SLAMTEC. The system ranges more than 32000 times per second. During every ranging process, the RPLIDAR emits modulated infrared laser signal, which is then reflected by the object to be detected. The returning signal is then sampled by the laser acquisition system in RPLIDAR, and the processor embedded in RPLIDAR starts processing the sample data and outputs the distance value and angle value between the object and RPLIDAR via the communication interface.

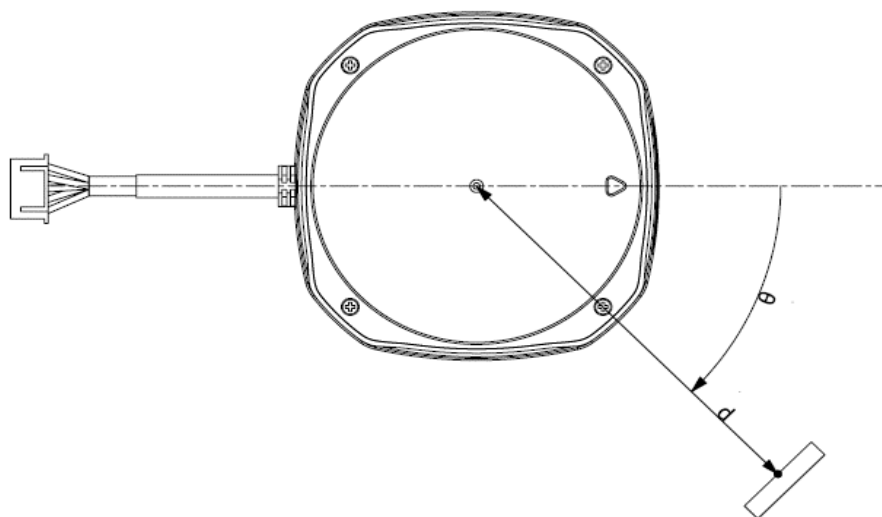
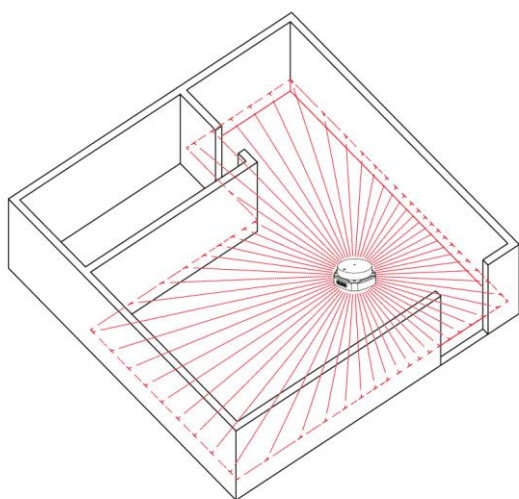

Figure 1-2 The RPLIDAR S2L Working Schematic

When driven by the motor system, the range scanner core will rotate clockwise and perform the 360-degree scan for the current environment.



\*Note: The LIDAR scan image is not directly relative to the environment shown here. Illustrative purposes only.

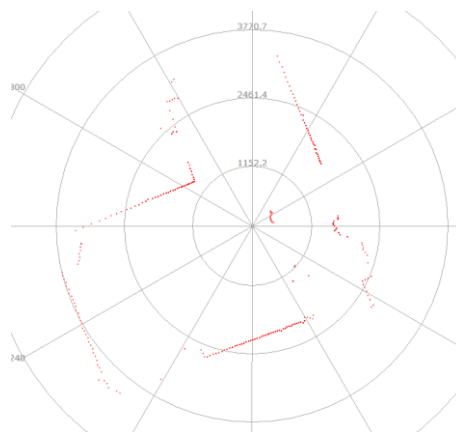

Figure 1-3 The Environment Map Obtained from RPLIDAR Scanning

## Safety and Scope



Class I

The RPLIDAR system uses a low-power infrared laser as its light source and drives it by using modulated pulse. The laser emits light in a very short time frame which can ensure the safety of humans and pets, and it reaches the Class I laser safety standard. Complies with 21 CFR 1040.10 and 1040.11 except for deviations pursuant to Laser Notice No. 50, dated June 24, 2007.

Caution: Use of controls or adjustments or performance of procedures other than those specified herein may result in hazardous radiation exposure.

The modulated laser can effectively avoid interference from ambient light and sunlight during the ranging and scanning process, which makes the RPLIDAR S2L work excellently in all kinds of indoor environments and outdoor environments without direct sunlight.

## Data Output

During the working process, the RPLIDAR will output the sampling data via the communication interface. The sample point data per frame contains the information in the following table. For the specific data format, refer to the "EXPRESS\_SCAN Command Request and Response Data Format" in the *S2L S2LL Communication Protocol*.

Data Type	Unit	Description
Distance Value	mm	Current measured distance value between the rotating core of the RPLIDAR and the sample point
Angle	Degree	Angle of the current sample point relative to the orientation of the RPLIDAR
Start Signal	(Boolean value)	Flag of a new scan
Checksum	-	Checksum of the data returned by the RPLIDAR

*Figure 1-4 The RPLIDAR Sample Point Data Information*

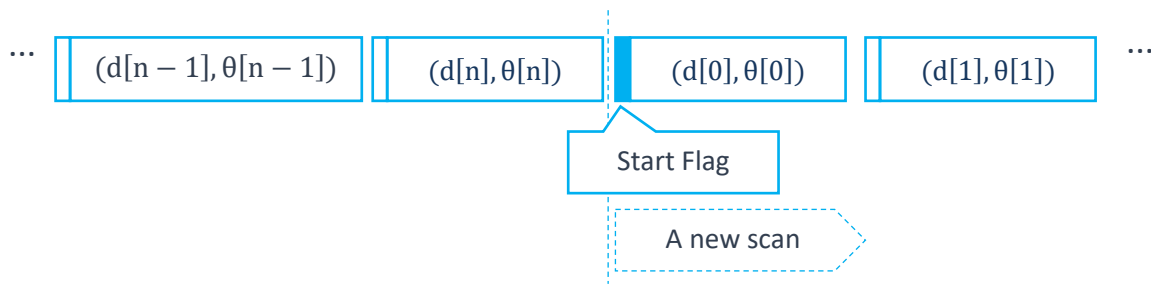

Figure 1-5 The RPLIDAR Sample Point Data Frames

The RPLIDAR outputs sample data continuously, and it contains the sample point data frames in the above figure. The host system can configure the output format and stop the RPLIDAR from outputting data by sending a control command. For the specific operation, refer to the *S2 S2L Communication Protocol* or contact SLAMTEC.

## High-Speed Sampling Protocol and Its Compatibility

The RPLIDAR S2L adopts the high-speed sampling protocol for outputting the 32000 times per second laser range scan data. Users are required to update the matched SDK or modify the original driver and use DenseBoost in the high-speed sampling protocol for the 32000 times per second mode of the RPLIDAR S2L. Please check the related protocol documents for details.

The RPLIDAR S2L is compatible with all communication protocols used by previous RPLIDAR products and can be used directly in place of previous RPLIDAR models. However, the RPLIDAR S2L will work in compatibility mode, and the scope of laser ranging will be limited. For details, refer to the communication protocols used by previous RPLIDAR products.

## Application Scenarios

The system can be used in the following application scenarios:

- General simultaneous localization and mapping (SLAM)
- Environment scanning and 3D re-modeling
- Service robots or industrial robots working for long hours
- Navigation and localization of home service/cleaning robots
- General robot navigation and localization
- Localization and obstacle avoidance of smart toys



## Measurement Performance

For Model S2M1-R2 Only

Item	Detail
Application Scenarios	Ideal for both outdoor and indoor environments with reliable resistance to daylight
Distance Range	White object: 0.05-18 meters (under 90% reflection)
	Black object: 0.05-8 meters (under 10% reflection)
Scan Field Flatness	0°-1.5° (other angle requirements can be customized)
Sample Rate	32kHz
Scanning Frequency	10Hz
Angular Resolution	0.12°
Communication Interface	TTL UART
Communication Speed	1M
Accuracy	±50mm*
Resolution	13mm*

Figure 2-1 RPLIDAR Performance

Note: Under 90% reflection, \* means the typical value. The actual value depends on environmental conditions.

## Laser Power Specification

For Model S2L Only

Item	Unit	Min	Typical	Max	Remarks
Working Wavelength	Nanometer (nm)	895	905	915	Infrared Light Band
Laser Power	Watt (W)	-	25	-	Peak power
Pulse Length	Nanosecond (ns)	-	5	-	-
Laser Safety Class	-	-	IEC-60825 Class 1	-	-

Figure 2-2 RPLIDAR Optical Specification

\*Note: The laser power is the power for continuous light emission, and the actual average power will be much lower than this value.

## Optical Window

To make the RPLIDAR S2L work normally, ensure proper space is left for emitting and receiving laser lights when designing the host system. The ranging window is partly obscured by the host system, which will impair the performance and resolution of the RPLIDAR S2L. If you need to cover the RPLIDAR with translucent materials or have other special needs, please contact SLAMTEC to learn about the feasibility.

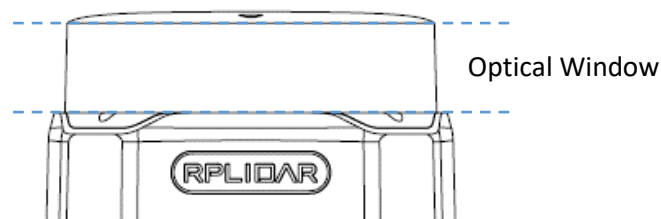

Figure 2-3 RPLIDAR Optical Window

You can check the Mechanical Dimensions chapter for detailed window dimensions.

## Coordinate System Definition of Scanning Data

The RPLIDAR S2L adopts a coordinate system of the left hand. The dead ahead of the sensors is the x-axis of the coordinate system; the origin is the rotating center of the range scanner core. The rotation angle increases as the device rotates clockwise. The detailed definition is shown in the following figure:

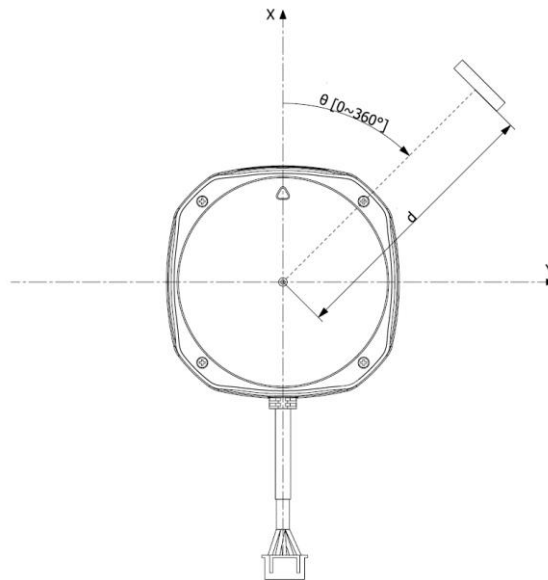

Figure 2-4 RPLIDAR S2L Scanning Data Coordinate System Definition

## Communication Interface

The RPLIDAR S2L uses separate 5V DC power to power the ranging system and the motor system. And the standard RPLIDAR S2L uses an XH2.54-5P male socket. The detailed interface definition is shown in the following figure:

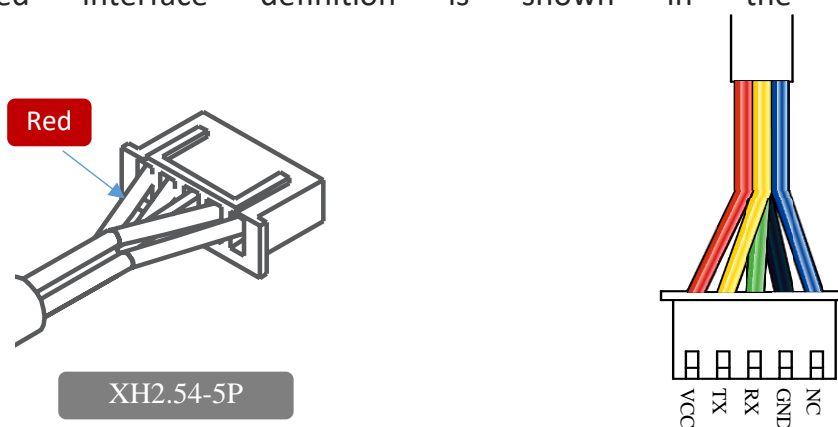

Figure 2-5 RPLIDAR Power Interface Definition

Color	Signal Name	Type	Description	Min	Typical	Max
Red	VCC	Power	Total Power	4.9V	5V	5.2V
Yellow	TX	Output	Serial port output of the scanner core	0V	/	3.5V
Green	RX	Input	Serial port input of the scanner core	0V	/	3.5V
Black	GND	Power	GND	0V	0V	0V
Blue	NC	/	Advise grounding	/	/	/

Figure 2-6 RPLIDAR S2L External Interface Signal Definition

## Power Supply Interface

The RPLIDAR S2L takes the only external power to power the range scanner core and the motor system, which makes the core rotate. To make the RPLIDAR S2L work normally, the host system needs to ensure the output of the power and meet its requirements of the power supply ripple.

For Model S2L Only

Item	Unit	Min	Typical	Max	Remarks
Power Voltage	V	4.9	5	5.2	If the voltage is not enough, the measurement will not be accurate.
Power Voltage Ripple	mV	-	-	150	Excessive power supply noise may cause increased radar radiation.
System Start Current	mA	-	1500	-	The system startup requires a relatively higher current.
Power Current	mA	-	500	600	5V Power, 10Hz scanning frequency

Figure 2-7 RPLIDAR Power Supply Specification

\*Note: An insufficient power supply may lead to inaccurate range measurement and insufficient motor speed during cold start. It is recommended to provide a sufficient power supply to the radar. The voltage measured at the external interface of the radar is more than 5V when the radar is working normally.

## Data Communication Interface

The RPLIDAR S2L takes the 3.3V-TTL serial port (UART) as the communication interface. The table below shows the transmission speed and the protocol standard.

Item	Unit	Min	Typical	Max	Remarks
Baud Rate	M	-	1	-	-
Working Mode	-	-	8 data bits, 1 stop bit, no parity check	-	8n1
Output High Voltage	V	2.9	3.3	3.5	Output signal with high voltage
Output Low Voltage	V	-	-	0.4	Output signal with low voltage
Input High Voltage	V	2.4	3.3	3.5	Input signal with high voltage
Input Low Voltage	V	0	-	0.4	Input signal with high voltage

Figure 2-8 RPLIDAR Serial Port Interface Specifications

## Scanner Motor Control

The RPLIDAR S2L is embedded with a closed motor control system that can control the rotation speed accurately. Users can change the rotation speed of the motor by sending a motor speed setting command to the RPLIDAR.

\*Note: However, the motor can't start or stop alone, and its working state depends on the laser scan command. If you want to control the rotation speed of the radar, provide a sufficient power supply to the radar.

## Miscellaneous

For Model S2L Only

Item	Unit	Min	Typical	Max	Remarks
Weight	Gram (g)	TBD	185	TBD	
Switch-on Temperature	Degree Celsius (°C)	0	-	-	
Working Temperature Range	Degree Celsius (°C)	-10	25	50	
Storage Temperature Range	Degree Celsius (°C)	-20	25	60	

*Figure 2-9 RPLIDAR Miscellaneous Specification*

The RPLIDAR S2L comes with laser power detection and sensor health check logic to avoid damage to the device due to malfunction and to ensure that the laser always works within the safety range during its operation. To avoid damage to the device and others, the RPLIDAR S2L will shut down the laser and stop scanning automatically when any of the following errors has been detected.

- The scan speed of the laser scanner system is unstable
- The scan speed of the laser scanner system is too slow
- The laser signal sensor works abnormally

The host system can check the system status via the communication interface and restart the RPLIDAR S2L to try to recover work from errors.

To facilitate the usage of RPLIDAR S2L in product development and speed up the development for users, SLAMTEC has provided the Framgrabber plugin in RoboStudio for testing and debugging as well as the SDK available under x86 Windows, x86 Linux, and Arm Linux. Please contact SLAMTEC for details.

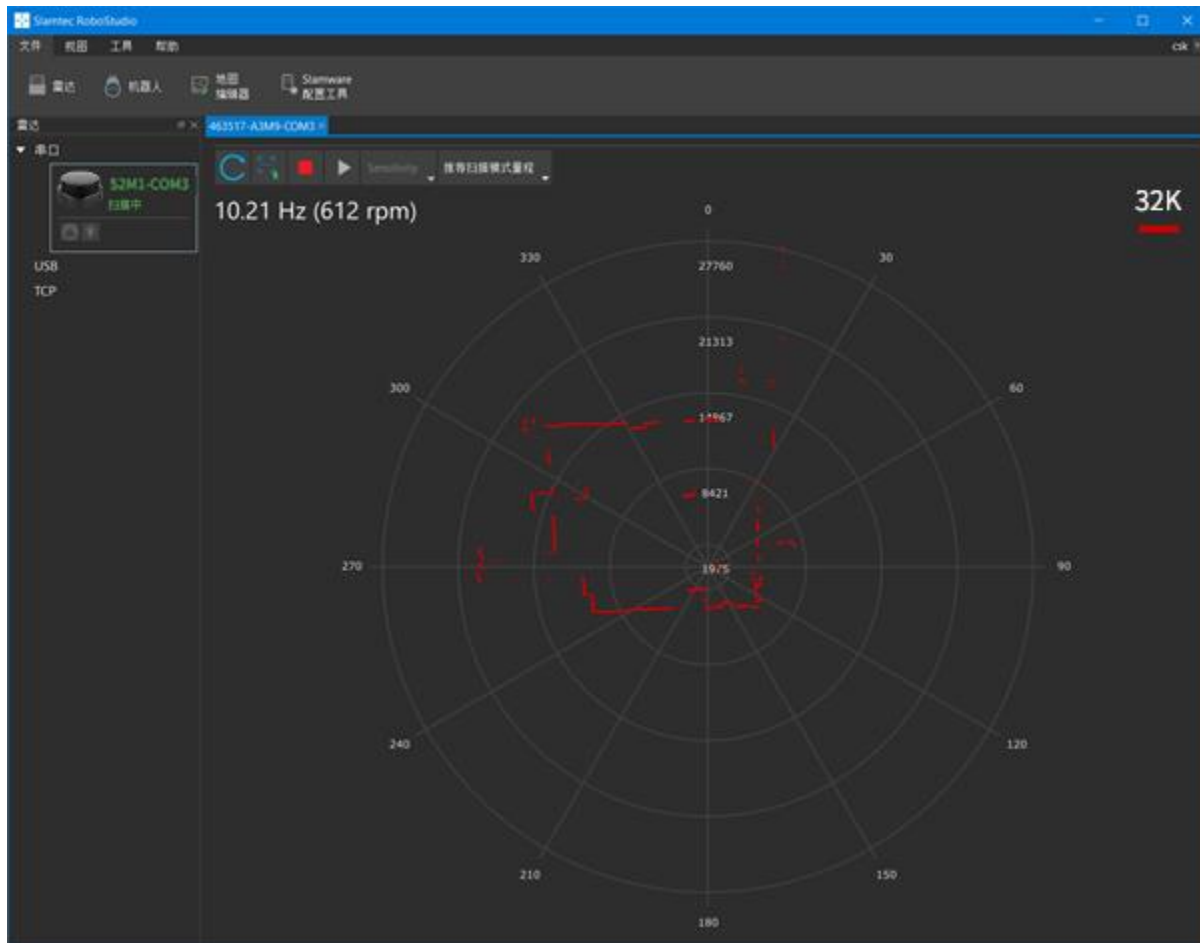

Figure 3-1 The Framegrabber Plugin in RoboStudio



The mechanical dimensions of the RPLIDAR S2L are shown below:

\*Note:

1. The depth of 4\*M3 screws in the bottom should be no longer than 4mm. Otherwise, the internal components will be damaged.
2. Dimension unit: mm; tolerance:  $\pm 0.2$ .

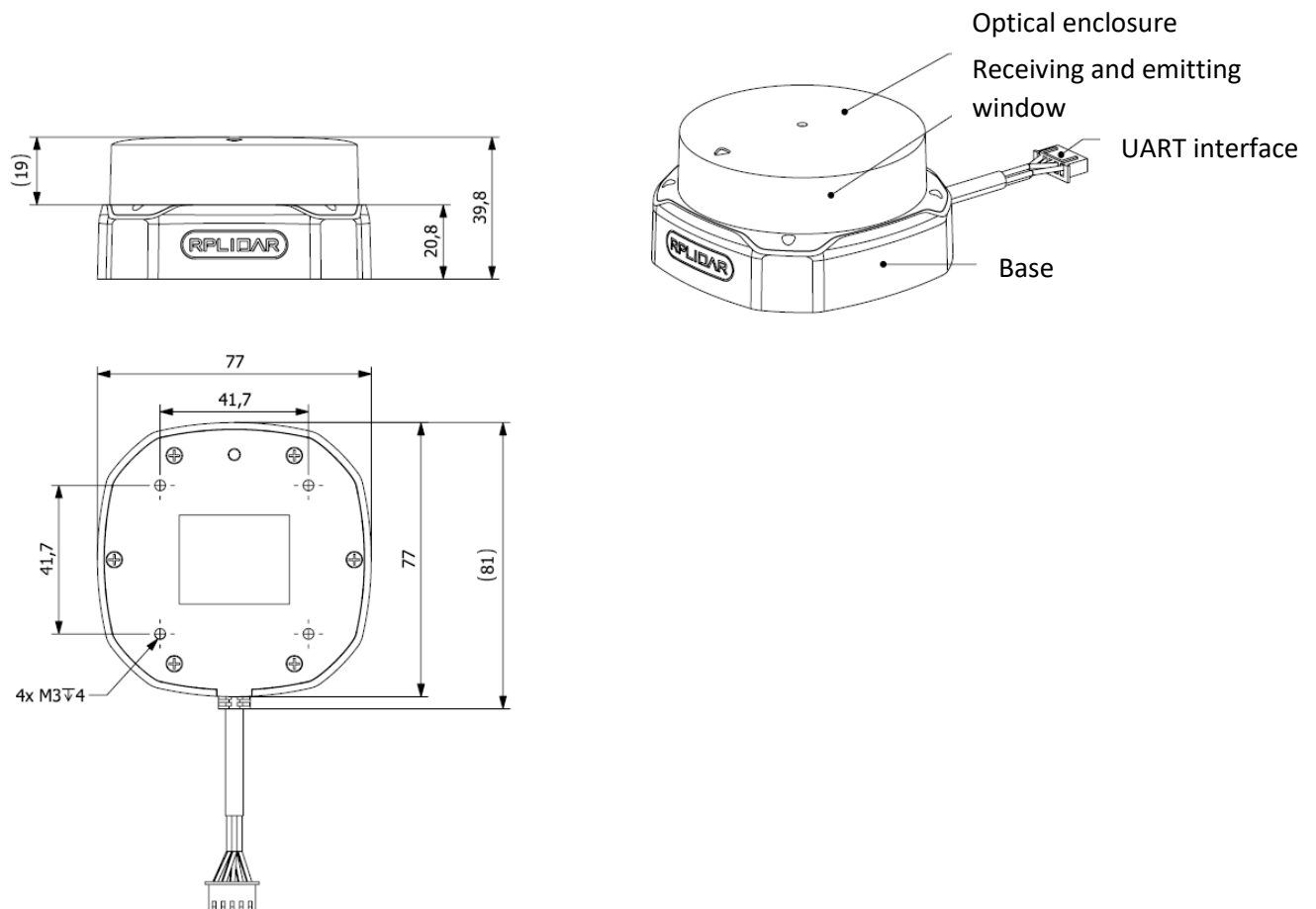

Figure 4-1 RPLIDAR S2L Mechanical Dimensions

Date	Version	Description
2021-07-28	1.0	Initial version for S2L
2021-12-15	1.1	Not connect MOTOCTL
2022-05-13	1.2	Add scan field flatness and correct the power voltage ripple and remarks
2022-06-20	1.3	Update accuracy values in Figure 2-1 and increase the range resolution
2022-11-24	1.4	Add reflection for black objects
2023-05-04	2.0	S2L version 2.0
2024-04-12	2.1	Update working temperature range and add switch-on temperature in Figure 2-9

## Image and Table Index

FIGURE 1-1 RPLIDAR S2L SYSTEM COMPOSITION.....	4
FIGURE 1-2 THE RPLIDAR S2L WORKING SCHEMATIC.....	5
FIGURE 1-3 THE ENVIRONMENT MAP OBTAINED FROM RPLIDAR SCANNING.....	5
FIGURE 1-4 THE RPLIDAR SAMPLE POINT DATA INFORMATION.....	6
FIGURE 1-5 THE RPLIDAR SAMPLE POINT DATA FRAMES.....	7
FIGURE 2-1 RPLIDAR PERFORMANCE.....	9
FIGURE 2-2 RPLIDAR OPTICAL SPECIFICATION.....	10
FIGURE 2-3 RPLIDAR OPTICAL WINDOW.....	10
FIGURE 2-4 RPLIDAR S2L SCANNING DATA COORDINATE SYSTEM DEFINITION.....	11
FIGURE 2-5 RPLIDAR POWER INTERFACE DEFINITION.....	11
FIGURE 2-6 RPLIDAR S2L EXTERNAL INTERFACE SIGNAL DEFINITION.....	12
FIGURE 2-7 RPLIDAR POWER SUPPLY SPECIFICATION.....	12
FIGURE 2-8 RPLIDAR SERIAL PORT INTERFACE SPECIFICATIONS.....	13
FIGURE 2-9 RPLIDAR MISCELLANEOUS SPECIFICATION.....	14
FIGURE 3-1 THE FRAMEGRABBER PLUGIN IN ROBOSTUDIO.....	16
FIGURE 4-1 RPLIDAR S2L MECHANICAL DIMENSIONS.....	17

**SHANGHAI SLAMTEC CO., LTD.**

**Address: E-10F Shengyin Tower, 666 Shengxia Rd., Shanghai, China  
5F, Building K, 188 Liaoyang Road, Yangpu District, Shanghai, China  
Made in China**