

版本 / Rev.	日期 / DATE	说明 / DESCRIPTION	备注 / REMARK	批准 / APPROVER

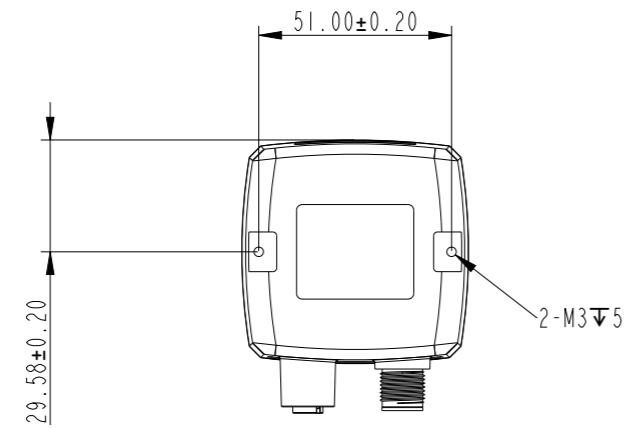

材料 / MATERIAL		重量 / WEIGHT		数量 / QUANTITY 1 PC.		SLAMTEC 上海思岚科技有限公司 Shanghai Slamtec Co., Ltd	
表面处理 / FINISH		比例 / SCALE 1:2		料号 / DESCRIPTION:			
选择 / SELECT V		单位 / UNIT MM		名称 / PART NAME:		项目 / PROJECT:	
尺寸 / DIM	公差 / TOL	A	B	C	D	EXTRA	图号 / DRAWIN NO.:
~25	±0.05	±0.08	±0.10	±0.20			版本 / REVISION:
25-80	±0.08	±0.12	±0.20	±0.30			检查 / CHECKED:
80-250	±0.12	±0.20	±0.30	±0.50			批准 / APPROVED:
250-500	±0.20	±0.30	±0.50	±0.80			
500~	±0.30	±0.50	±0.80	±1.20			

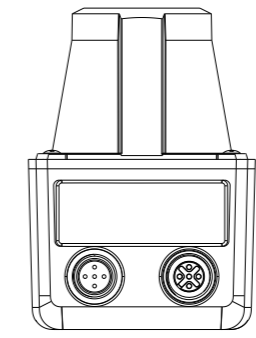
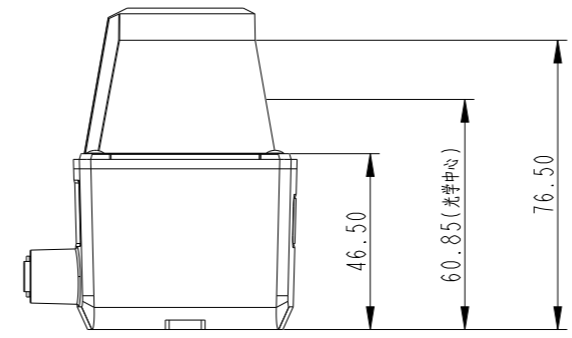
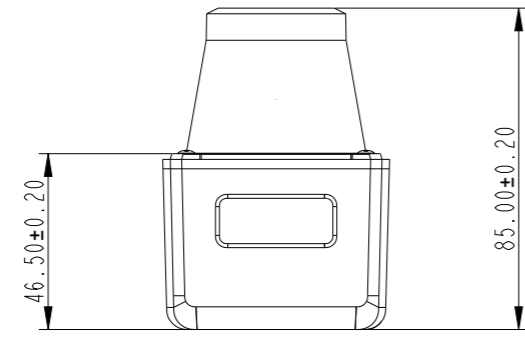
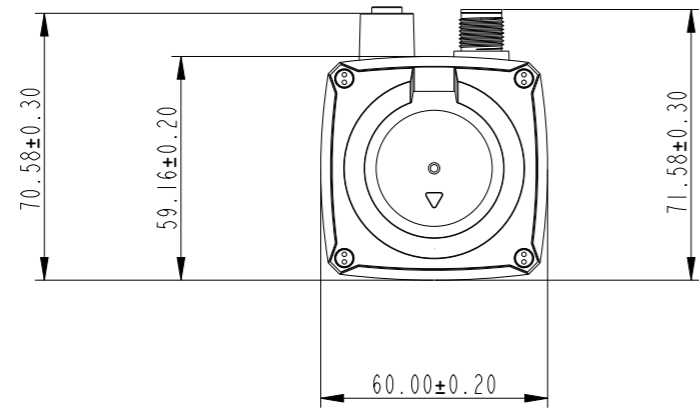